



Date: _____ Driver: _____
 Event: _____ Car: _____
 Track: _____ Weight: _____

SETUP SHEET



TRACK CONDITIONS

Surface: Smooth Med. Bumpy
 Size: Open Med. Tight
 Traction: High Med. Low

Track Temp/Air Temp: _____° / _____°
 Note: _____

FRONT SUSPENSION

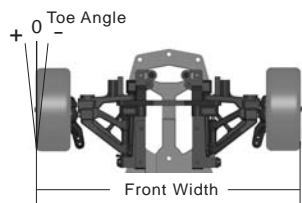

Front Width: _____ mm

Anti-Roll Bar: _____°

Diff. Fluid: _____ wt
 One Way
 Solid Axle

Toe Angle: _____°

Front Camber: L _____° R _____°

Front Ride Height: _____ mm

Front Droop: _____ mm

Caster: _____ mm

► SHOCK

Shock Length: _____ mm

Thread Length: _____ mm

Oil: _____ wt

Piston: _____

Spring: _____ mm

► TIRE

Front Tire: _____

Shore: L _____° R _____°

Diameter(Start): L/R _____ / _____ mm

Diameter(Finish): L/R _____ / _____ mm

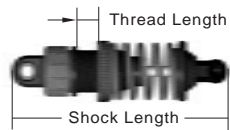
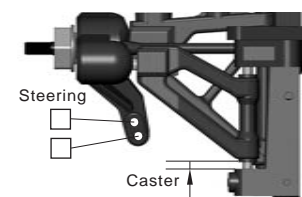
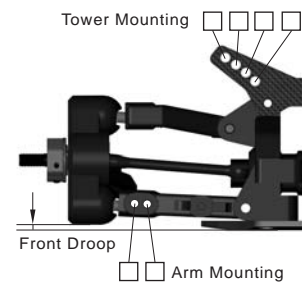
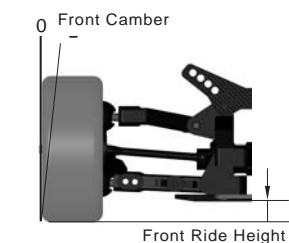

REAR SUSPENSION

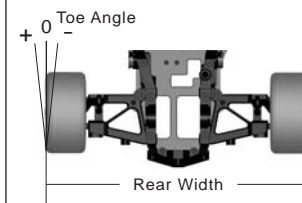

Rear Width: _____ mm

Anti-Roll Bar: _____°

Diff. Fluid: _____ wt
 Solid Axle

Toe Angle: _____°

Rear Camber: L _____° R _____°

Rear Ride Height: _____ mm

Rear Droop: _____ mm

► SHOCK

Shock Length: _____ mm

Thread Length: _____ mm

Oil: _____ wt

Piston: _____

Spring: _____ mm

► TIRE

Front Tire: _____

Shore: L _____° R _____°

Diameter(Start): L/R _____ / _____ mm

Diameter(Finish): L/R _____ / _____ mm

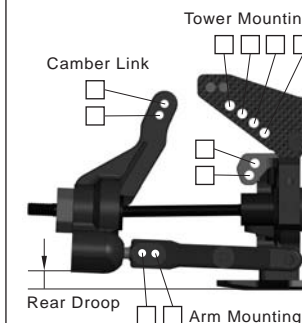
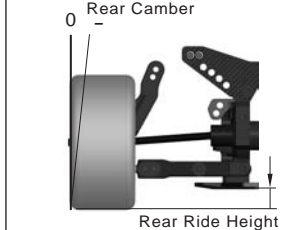

Pulley

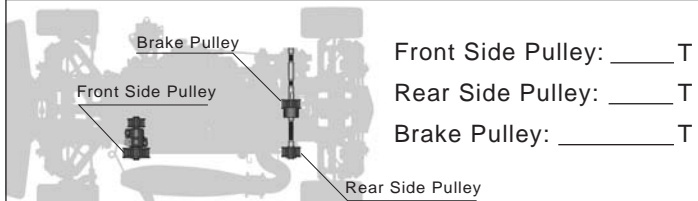

Front Side Pulley: _____ T

Rear Side Pulley: _____ T

Brake Pulley: _____ T

ENGINE

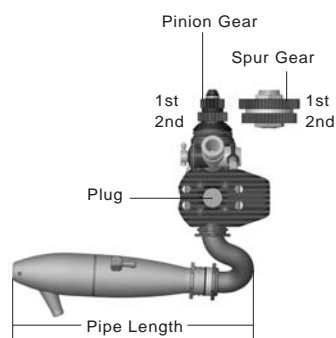

Gear Ratio: 1st _____ T / _____ T

2nd _____ T / _____ T

Clutch Set Type:

3 Shoe Push Type

Clutch Spring: _____ mm

Clutch weight: _____

Clutch Shoe: _____

Engine: _____

Plug: _____

Fuel: _____

Manifold: _____

Pipe: _____

Pipe Length: _____ mm

Note: _____

Body

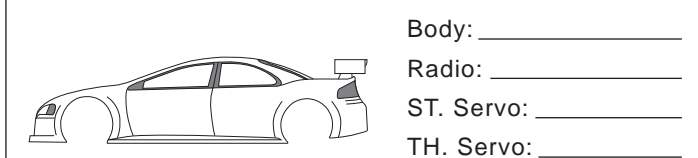

Body: _____

Radio: _____

ST. Servo: _____

TH. Servo: _____

COMMENTS

Race Time / Lap: _____
 Best Lap Time: _____
 Position: _____
 Notes: _____
